

PAPER • OPEN ACCESS

Preliminary analysis of the influence of environmental boundary conditions on convective heat transfer coefficients

To cite this article: Luca Evangelisti *et al* 2021 *J. Phys.: Conf. Ser.* **1868** 012024

View the [article online](#) for updates and enhancements.

You may also like

- [Performance Simulation of Tubular Segmented-in-Series SOFC Using Simplified Equivalent Circuit](#)
Shun Yoshida, Tadashi Tanaka and Yoshitaka Inui
- [\(Invited\) Potential of Double Network Gel as a Tribological Material Realizing Low Friction in Water](#)
Koki Kanda and Koshi Adachi
- [Analysis of the Effect of Surface Diffusion on Effective Diffusivity of Oxygen in Catalyst Layer By Direct Simulation Monte Carlo](#)
Tomoki Hori, Takuya Mabuchi, Ikuya Kinefuchi *et al.*



UNITED THROUGH SCIENCE & TECHNOLOGY

 **The Electrochemical Society**
Advancing solid state & electrochemical science & technology

**248th
ECS Meeting**
Chicago, IL
October 12-16, 2025
Hilton Chicago

**Science +
Technology +
YOU!**

**Register by
September 22
to save \$\$**

REGISTER NOW

Preliminary analysis of the influence of environmental boundary conditions on convective heat transfer coefficients

Luca Evangelisti¹, Claudia Guattari¹ and Tullio de Rubeis²

¹ Roma TRE University, Department of Engineering, Via Vito Volterra 62, 00144 Rome (Italy)

² University of L'Aquila, Department of Industrial and Information Engineering and Economics (DIIE), Piazzale Pontieri 1, Monteluco di Roio, I 67100 L'Aquila (Italy)

Corresponding author's e-mail: tullio.derubeis@univaq.it

Abstract. In this contribution, a hot box apparatus was used to investigate convective heat transfers through an experimental setup composed of a heat-flow sensor, air and surface temperature probes installed on the wall tested in the hot box and a hot-wire anemometer. The air near the wall was indirectly moved by means of a forced convection system through which the air velocity can be modified to simulate different environmental conditions. The hot box apparatus was used in order to investigate the influence of the air velocity on internal convective heat transfer coefficients (h_c), under natural/mixed convection conditions. The Standard ISO 6946 suggests a typical internal convective heat transfer coefficient equal to 2.5 W/m²K when horizontal heat fluxes occur. No detailed information about this value are reported in the Standard. So, the final aim of this study is to assess the applicability of the internal convective heat transfer coefficient value proposed by ISO 6946 under different air velocity values, quantifying how h_c varies as air velocity changes.

1. Introduction

The construction sector is known to be one of the main energy-consuming sectors, depleting around 40% of the total [1] and producing around 30% of greenhouse gas emissions (more than redoubled since 1970 [2]). The reduction of greenhouse gas emissions deriving from the building sector is nowadays a primary goal. According to this, the thermal behavior of building components strongly influences the annual energy needs of buildings, and the comprehension of the actual thermal behavior of the buildings' envelopes is a key factor.

One of the most significant property of walls is the thermal transmittance (U-value), which can be measured or calculated, in function of the knowledge of walls stratigraphy. When the thermophysical properties of each layer of a wall are known, it is possible to compute the U-value, considering for the inner and outer wall surfaces total heat transfer coefficients whose values are commonly defined and largely used. These heat transfer coefficients derive from the Standard ISO 6946 [3]. Taking into consideration the inner side of a wall, for horizontal heat fluxes, the internal total heat transfer coefficient is a function of convective and radiative heat transfers; the contribution of convection is quantified through a default value of 2.5 W/m²K, whose origin is not specified in the Standard. This is certainly different for the radiative coefficient, which is a function of the wall surface emissivity and its temperature [4].



The analysis of suitable heat transfer coefficients becomes essential for obtaining U-values closer to reality or for calculating heat fluxes by means of indirect approaches. Indeed, heat flows can be obtained indirectly, using temperature probes and setting an appropriate heat transfer coefficient [5]. In recent years, not many experimental scientific papers have been published studying heat transfer coefficients in the building sector. Taking into consideration heat fluxes transferred between fluids and solids, the calculation of the surface thermal resistance requires the knowledge of all the parameters necessary to define the heat transfer coefficient. Knowing the right value of these properties is challenging.

In this study, a hot box system was used to investigate convective heat transfers through an experimental setup composed of surface temperature probes installed on the sample wall and air temperature probes inside the metering box close to the wall tested in the hot box. The air near the wall was indirectly moved by means of a forced convection system, consisting of a small fan which allowed to vary the air velocity in order to simulate different environmental conditions. An anemometer was used to measure the air velocity near the sample wall. Exploiting the hot box morphology, characterized by two main chambers (hot and cold) and the building component under investigation interposed between them, known and repeatable thermal conditions can be generated for reproducing a thermal stress that characterizes the actual use of the wall [6, 7].

The hot box apparatus was used in order to apply a methodological approach based on the dimensionless parameters analysis but having controlled boundary conditions. In this way, the influence of the air velocity on convective heat transfer coefficients can be assessed, under natural/mixed convection conditions. As mentioned before, the Standard ISO 6946 suggests a typical internal convective heat transfer coefficient (h_c) equal to 2.5 W/m²K when horizontal heat fluxes occur. No detailed information about this value are reported in the Standard.

So, the aims of this study are: assessing the applicability of the internal convective heat transfer coefficient value proposed by the Standard under different air velocity values, quantifying how h_c varies as air velocity changes; proposing a suitable methodological approach for experimentally identifying surface heat transfer coefficients (also useful for indirect heat flow measurements), thus not applying existing correlations that may not be representative for the investigated case studies.

2. Materials and methods

2.1. The experimental setup

In this research the hot box system located in the laboratories of the University of L'Aquila was used. The employed Guarded Hot Box (GHB), whose detailed description is presented in [6, 8-9], is widely used to study the thermal behavior of sample walls [10- 13], thanks to the possibility of reproducing conventional and repeatable boundary conditions of a specimen placed between two fluids. It consists of two main chambers (hot and cold) and a specimen, placed between them and object of analysis. The hot chamber is in turn composed of a metering box surrounded by a guard box in which the environment is controlled. The control of the thermal conditions inside the GHB is ensured by a control unit that controls three slave units intended for: i) hot chamber (measuring and guard boxes); ii) cold box; iii) specimen wall. Each unit allows the control of temperature probes (surface and air) and of the machines that regulate the thermal conditions, i.e. electric resistances and cooling unit. The temperature probes installed in the GHB make it possible to determine the surface temperature of the wall (both hot and cold side), the radiant temperature (i.e. the temperature of surfaces "seen" by the specimen), and the air temperatures (hot and cold side). The sensors distribution has been carried out in accordance with the standard UNI EN ISO 8990 [14] and the schematic representation of the hot box is shown in Figure 1.

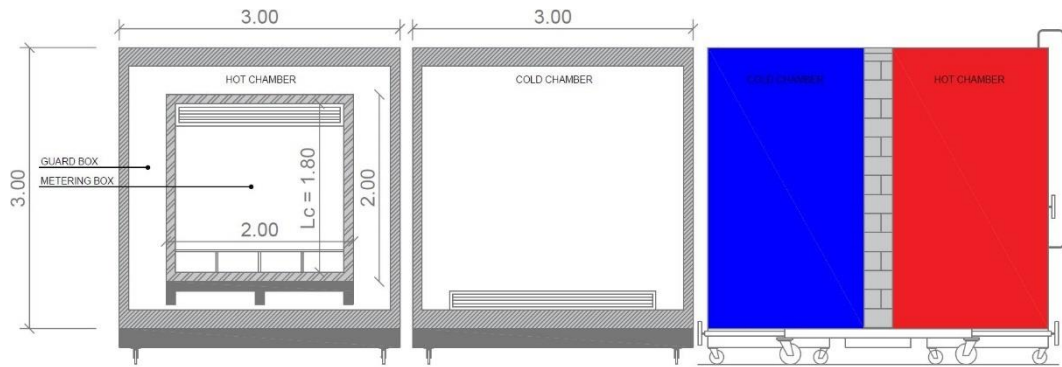

Fig. 1. Simplified representation of the hot box main components (Dimensions in meters. L_c is the Nusselt number characteristic length).

The specimen wall is made up of an X-lam panel structural member (solid wood with crossed layers, also known as Cross Laminated Timber (CLT)) with double insulation represented by mineral wool (facing the hot chamber) and Expanded Polystyrene (EPS) and graphite (facing the cold chamber) (see Figure 2).

The X-lam panel and the insulation layers are plastered on both sides with a total thickness equal to 30 cm. Thanks to the presence of the double insulation and to the nature of the wooden structural member, the analyzed wall is characterized by high thermal performance, with a theoretical U-value equal to $0.176 \pm 0.030 \text{ W/m}^2\text{K}$ (*Remark:* the uncertainty of the U-value was determined using the Holman’s method [15]). The dimensions of the specimen are equal to $3 \text{ m} \times 3 \text{ m}$. The thermophysical properties of each layer of the tested wall are listed in Table 1.

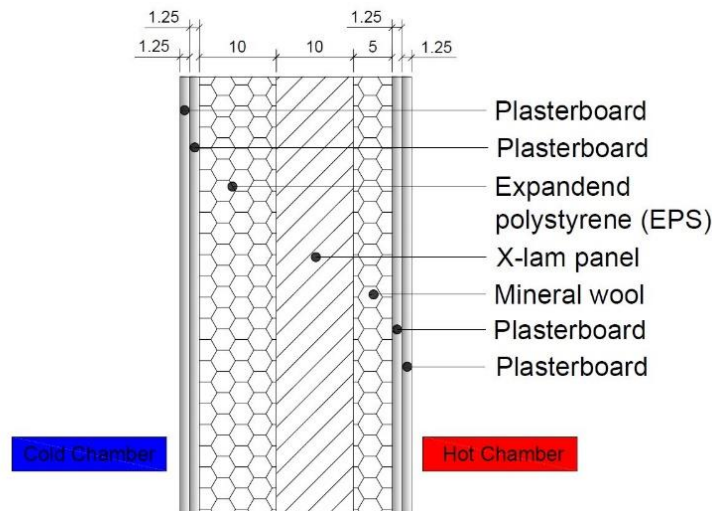

Fig. 2. Stratigraphy of the specimen wall (dimensions in centimeters).

Table 1. Thermophysical properties of the specimen wall stratigraphy (from outside to inside).

Layer	Thickness [cm]	Thermal conductivity [W/mK]	Mass density [kg/m ³]	Specific heat capacity [J/kgK]
Plasterboard	1.25	0.210	900	1000
Plasterboard	1.25	0.210	900	1000
EPS and graphite	10.00	0.031	32	1350
X-lam panel	10.00	0.130	470	1600

Mineral wool	5.00	0.039	135	850
Plasterboard	1.25	0.210	900	1000
Plasterboard	1.25	0.210	900	1000

The technical specifications of the measuring instruments used in the experimental phase of this work are summarized in Table 2. Sensors have been installed using a specific thermal compound to reduce the effects of the contact thermal resistances.

Table 2. Technical specifications of the measuring instruments.

Instrument	Type	Measuring range	Resolution
Heat flux sensor	Hukseflux HFP01	-2000 to 2000 W/m ²	60 x 10 ⁻⁶ V/(W/m ²)
Temperature probes (Surface)	LSI Lastem EST124-Pt100	-50 to +70 °C	0.01 °C
Temperature probes (Air)	Maxim Integrated DS18B20	-55 to +125 °C	0.0625 °C
Hot-wire anemometer	LSI Lastem ESV107	0.01 to 20 m/s	0.01 m/s
Datalogger	LSI Lastem M-Log ELO008	-300 to +1200 mV	40 μV

2.2. ISO 6946

The ISO 6946 is applied for calculating building walls thermal resistances. The total thermal resistance of a wall can be defined as the sum of the thermal resistances of each single wall layers, also taking into consideration the surface thermal resistances (R_s). Surface thermal resistances are defined in function of the convective (h_c) and radiative (h_r) heat transfer coefficients, which can be computed for the internal and external surfaces of the wall. The sum of h_c and h_r is represented by the total heat transfer coefficient (h_{tot}). Surface thermal resistances can be defined as follows:

$$R_s = \frac{1}{h_c + h_r} = \frac{1}{h_{tot}} \quad (1)$$

Considering horizontal heat fluxes, the ISO 6946 recommends an internal surface thermal resistance value equal to 0.13 m²K/W, which corresponds to a h_{tot} equal to 7.69 W/m²K. The convective contribution corresponds to a h_c coefficient equal to 2.5 W/m²K (the Standard does not provide any information about this value).

The radiative contribution can be defined through the following formula:

$$h_r = 4\varepsilon_s\sigma T_m^3 \quad (2)$$

where ε_s is the emissivity of the building exposed surface, σ is the Stefan-Boltzmann constant and T_m is the average thermodynamic temperature of the surface and the surrounding surfaces. Considering horizontal heat fluxes, the ISO 6946 recommends an internal surface thermal resistance value equal to 0.13 m²K/W, which is calculated considering a wall surface emissivity equal to 0.9 and a temperature of 20 °C. If, as mentioned, the convective part is represented by a h_c value of 2.5 W/m²K, the radiative part can be deduced subtracting h_c from the total heat exchange coefficient, obtaining a radiative heat transfer coefficient equal to 5.19 W/m²K.

2.3. Methodological approach

The GHB is equipped with a heat-flow meter sensor installed on the hot side of the specimen wall, two air temperature probes for monitoring the air temperature in the metering box, and surface temperature probes applied for registering data related to the surface temperatures of the wall and the baffle.

After reaching steady state conditions in the hot box, the mentioned arrangement of the sensors allowed to apply the following procedure. Convective heat transfer coefficients can be obtained following an approach based on the study of the dimensionless groups related to the convective heat transfer theory. Grashof number (Gr) is a well-known dimensionless number which can be defined in natural convection. On the contrary, Reynolds number (Re) can be associated to forced convection.

Natural or forced convection can be examined by calculating the Archimedes number (Ar):

$$Ar = \frac{Gr}{Re^2} \quad (3)$$

where, if Ar is much less than 0.7 the convection is purely forced; if Ar is much greater than 10 the convection is purely natural. Finally, if Ar is between 0.7 and 10, the convection is mixed. In natural convection, the h_c coefficient can be obtained by the Nusselt number (Nu), which in turn can be defined as a function of the Rayleigh number (Ra):

$$Nu = C \cdot Ra^n \quad (4)$$

where C and n are two constants depending on the geometrical characteristics and temperature of the analyzed surface. Considering vertical surfaces, the equations listed below [16] are commonly applied:

$$Nu = 0.59 \cdot Ra^{\frac{1}{4}}, \quad 10^4 < Ra < 10^9 \quad (5)$$

$$Nu = 0.10 \cdot Ra^{\frac{1}{3}}, \quad 10^9 < Ra < 10^{13} \quad (6)$$

In mixed convection, both natural and forced convection are significant. In this case, the following correlation can be used [16]:

$$Nu^3 = Nu_{forced}^3 + Nu_{natural}^3 \quad (7)$$

In particular, Nu_{forced} (the Nusselt number for forced convection) can be calculated through the following formula:

$$Nu = 0.664 \cdot Re^{\frac{1}{2}} \cdot Pr^{\frac{1}{3}} \quad (8)$$

where Pr is the Prandtl number.

Nu provides a measure of the convection heat transfer occurring at the surface and it is defined as a function of h_c and the geometrical characteristic length (in this case equal to the vertical dimension of the metering box, equal to 1.80 m). Therefore, the calculation of the Nusselt number allows to obtain the convective coefficient.

The procedure mentioned before was applied taking into consideration different values of the air velocity in the hot chamber. The air near the wall was indirectly moved by means of a convection system consisting of a small fan through which the air velocity can be modified to simulate different environmental conditions. An anemometer was used to measure the air velocity near the wall (see Figure 3). At first, the experimental measurements were conducted considering the ventilation system off (in this case, the air velocity measurements led to values less than the hot-wire anemometer resolution). Then, air velocities (v) equal to, 0.10 m/s and 0.15 m/s were tested.

A preliminary uncertainty assessment was performed following the Holman's method [15].

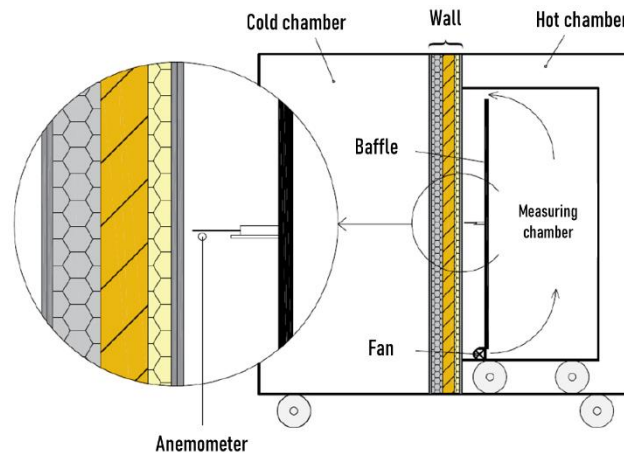

Fig. 3. Schematic representation of the hot box experimental set up.

3. Results and discussion

Measurements in the hot box were conducted for a period which is considered sufficient to obtain acceptable heat fluxes conditions, i.e. for a period sufficient to obtain heat fluxes converging to asymptotic values “close” to real values. Figure 4 shows the heat flux progressive average values, measured considering different air velocities. For the sake of simplicity, the ventilation system off condition was called $v = 0 \text{ m/s}$ in Figure 4. However, the air velocity is not zero but it was characterized by values lower than the resolution of the measuring instrument.

Table 3 lists the data obtained in steady state regime related to heat fluxes, air and surface temperatures in the hot and cold chambers. It is possible to observe that the heat flux raised as the air ventilation system was on.

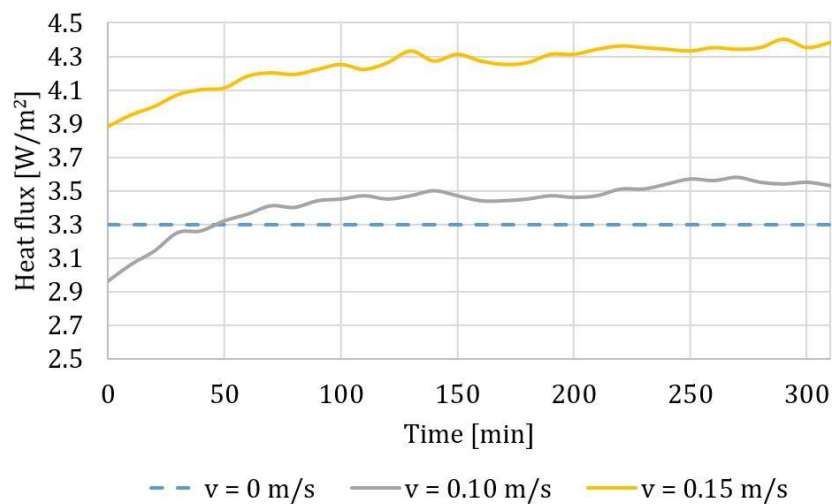

Fig. 4. Heat flows measured for different air velocity conditions (*Remark: the dotted line ($v = 0 \text{ m/s}$) shows the steady state value for reference purposes only*).

Table 3. Air velocities, heat fluxes, air and surface temperatures obtained in steady state regimes.

Case	Average air velocity [m/s]	Heat flux [W/m ²]	Air temperature hot chamber [°C]	Sample surface Temperature (hot side) [°C]	Baffle surface temperature hot chamber [°C]	Air temperature cold chamber [°C]
1	-	3.3 ± 0.1	20.1 ± 0.5	19.1 ± 0.1	20.3 ± 0.5	-0.1 ± 0.5
2	0.100 ± 0.083	3.5 ± 0.1	20.5 ± 0.5	19.4 ± 0.1	20.7 ± 0.5	-0.1 ± 0.5
3	0.150 ± 0.083	4.4 ± 0.1	21.1 ± 0.5	20.0 ± 0.1	21.3 ± 0.5	-0.1 ± 0.5

Considering both the air and surface temperatures, and the air velocities, the methodological approach based on the calculation of the dimensionless parameters was applied, taking into account a film temperature of about 20°C (an average representative value between the air temperature values and those of the wall surface), a kinematic viscosity equal to $1.50 \times 10^{-5} \text{ m}^2/\text{s}$ (a suitable value for a film temperature of 20°C) and a Prandtl number equal to 0.713 [16]. Moreover, taking into consideration the case characterized by the ventilation system off, an air velocity equal to 0.001 m/s was here considered for calculating the Reynolds number (thus obtaining a value greater than zero). This allowed to compute the dimensionless groups listed in Table 4.

Table 4. Dimensionless numbers for the analysed cases.

Case	Gr	Re	Ar	Ra	Nu (natural)	Nu (forced)
1	8.22×10^8	120	57089.85	5.86×10^8	83.69	-
2	9.59×10^8	12000	6.66	6.84×10^8	88.10	64.98
3	1.00×10^9	18000	3.09	7.13×10^8	89.35	79.59

It is worthy to notice that in Case 1 the convection was purely natural ($Ar \gg 10$). On the contrary, in Cases 2 and 3, the mixed convection occurred ($0.7 < Ar < 10$). The Nusselt number allowed to calculate the convective coefficients whose values are shown in Figure 5. Aiming at obtaining a correlation for h_c in function of the air velocity near the wall, a trendline (characterized by a R^2 greater than 0.99) was drawn. Comparing the h_c obtained by the correlation found and those obtained by the dimensionless groups, it is possible to observe that the correlation fit very well the experimental data, with percentage variations less than 1.5% for all the considered cases. Starting from Figure 5, the following correlation was found: $h_c = 1.9345 \cdot v + 1.3222$.

**Fig. 5.** Convective heat transfer coefficients (and trendline) obtained through the empirical method as a function of the air velocity.

Table 5 reported the comparison among the convective heat transfer coefficients derived from the empirical method and from the Standard ISO 6946. Making a comparison of the h_c from the empirical

approach and the value suggested by the Standard, percentage variations ranging from -46.96% to -35.36% can be observed. So, the experimental convective heat transfer coefficients are always characterized by values lower than that suggested by ISO 6946.

Table 5. Convective heat transfer coefficients obtained through the empirical method and from the ISO 6946, and percentage differences.

Case	h_c (Empirical method) [W/m ² K]	h_c ISO 6946 [W/m ² K]	Emp. Method vs ISO6946 difference [%]
1	1.33 ± 0.09	2.50	-46.96 ± 3.60
2	1.51 ± 0.21	2.50	-39.59 ± 8.40
3	1.62 ± 0.17	2.50	-35.36 ± 6.80

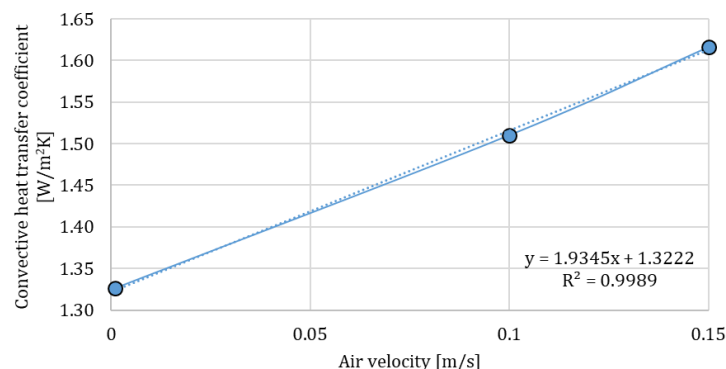
4. Conclusions

In this study, a GHB was used for investigating convective heat transfers through an experimental setup composed of air and surface temperature sensors installed on the wall tested in the hot box and a hot-wire anemometer. The air near the wall was indirectly moved by means of a forced convection system by imposing three different air velocity conditions. The methodological approach based on the dimensionless parameters analysis was applied to calculate the convective heat transfer coefficients in function of the air velocity in proximity of the wall and compare the results obtained with the Standard ISO 6946.

Natural and mixed convection conditions were identified: for air velocity close to 0 m/s natural convection obviously occurred; on the contrary, mixed convection occurred for 0.10 m/s and 0.15 m/s. For all the tested velocities, the experimentally h_c allowed to find a specific correlation for indoor environmental conditions, obtaining much lower values than the one suggested by the ISO 6946, with percentage differences ranging from -46.96% to -35.36%.

However, natural/forced convection in the baffle space could be also a parallel plates boundary condition. For this reason, this aspect will be better analyzed during the future research developments. This is a preliminary step of a research on total heat transfer coefficients. Future developments will regard the extension of the analysis to other air velocity values, the analysis of the radiative heat transfers in the GHB (radiative heat transfer is also a function of the geometrical parameters of the room and the view factors could cause strong variations of the radiation on a wall surface), and the comparison with total heat transfer that can be obtained from heat-flow and temperature measurements. Moreover, a more detailed evaluation of the measurement's uncertainties will be performed.

References

- [1] International Energy Agency (IEA). (2016). World Energy Outlook; IEA: Paris, France, 2016.
- [2] International Energy Agency (IEA). (2012). CO2 Emissions from Fuel Combustion. Beyond 2020 Online Database, International Energy Agency, Paris, 2012, p. 135. Available at: <http://data.iea.org>.
- [3] ISO 6946 - Building components and building elements – Thermal resistance and thermal transmittance.
- [4] L. Evangelisti, C. Guattari, P. Gori, R. de Lieto Vollaro, F. Asdrubali. (2016). Experimental investigation of the influence of convective and radiative heat transfers on thermal transmittance measurements, International Communications in Heat and Mass Transfer 78, 214–223.
- [5] L. Evangelisti, C. Guattari, F. Asdrubali. (2019). Comparison between heat-flow meter and Air-Surface Temperature Ratio techniques for assembled panels thermal characterization, Energy Build 2013, 109441.
- [6] T. de Rubeis, M. Muttillio, I. Nardi, L. Pantoli, V. Stornelli, D. Ambrosini. (2019). Integrated Measuring and Control System for Thermal Analysis of Buildings Components in Hot Box

- Experiments, *Energies* 12, 2053.
- [7] G. Woltman, M. Noel, A. Fam. (2017). Experimental and numerical investigations of thermal properties of insulated concrete sandwich panels with fiberglass shear connectors, *Energy and Buildings* 145, 22–31.
- [8] I. Nardi, D. Paoletti, D. Ambrosini, T. de Rubeis, S. Sfarra. (2015). Validation of quantitative IR thermography for estimating the U-value by a hot box apparatus, *Journal of Physics: Conference Series* 655, 012006.
- [9] T. de Rubeis, I. Nardi, M. Muttullo. (2017). Development of a low-cost temperature data monitoring. An upgrade for hot box apparatus. *IOP Conf. Series: Journal of Physics: Conf. Series* 923, 012039.
- [10] A.A. Lechowska, J.A. Schnotale, G. Baldinelli. (2017). Window frame thermal transmittance improvements without frame geometry variations: An experimentally validated CFD analysis. *Energy and Buildings* 145, 188–199.
- [11] A. Ghosh, S. Ghosh, S. Neogi. (2014). Performance evaluation of a guarded hot box U-value measurement facility under different software based temperature control strategies, *Energy Procedia* 54, 448–454.
- [12] F. Chen, S.K. Wittkopf. (2012). Summer condition thermal transmittance measurement of fenestration systems using calorimetric hot box. *Energy and Buildings* 53, 47–56.
- [13] K. Martin, A. Campos-Celador, C. Escudero, I. Gómez, J.M. Sala. (2012). Analysis of a thermal bridge in a guarded hot box testing facility. *Energy and Buildings* 50, 139–149.
- [14] UNI EN ISO 8990. Thermal Insulation—Determination of Steady-State Thermal Transmission Properties - Calibrated and Guarded Hot Box; International Standard Organization: Geneva, Switzerland, 1999.
- [15] J.P. Holman, *Experimental methods for engineers*, 8th ed.; McGraw-Hill series in mechanical engineering; ISBN-13: 978-0-07-352930-1.
- [16] T.L. Bergman, A.S. Lavine, F.P. Incropera, D.P. Dewitt. (2017). *Fundamentals of Heat and Mass Transfer*, John Wiley & Sons, ISBN 13 978-0470-50197-9.