



IV International Seminar on ORC Power Systems, ORC2017  
13-15 September 2017, Milano, Italy

# Performances of an ORC power unit for Waste Heat Recovery on Heavy Duty Engine

R. Cipollone<sup>a</sup>, D. Di Battista<sup>a\*</sup> and F. Bettoja<sup>b</sup>

<sup>a</sup>Department of Industrial and Information Engineering and Economics- University of L'Aquila - v. G. Gronchi, 18 – L'Aquila - Italy

<sup>b</sup>C.R.F. s.c.p.a. – Strada Torino, 50 – Orbassano (TO) – Italy

---

## Abstract

Reciprocating internal combustion engines (ICE) are still the most used in the sector of the on-the-road transportation, both for passengers and freight. CO<sub>2</sub> reduction is the actual technological driver, considering the worldwide greenhouse reduction targets committed by most governments. In ICE more than one third of the fuel energy used is rejected to the environment as thermal waste through the exhaust gases. Therefore, a greater fuel economy could be achieved, if this energy was recovered and converted into useful mechanical or electrical power. This recovery appears very interesting, in particular for those engines that run at almost steady working conditions, like marine, agricultural, industrial or long-hauling vehicle applications.

In this paper, an ORC-based power unit was tested on a heavy duty diesel engine. Energetic and exergetic analyses have been carried out in order to assess the real performances of the ORC unit and to individuate differences with the theoretical ones. A single stage impulse axial turbine has been tested in this work, complete with an electric variable speed generator and an AC/DC converter. The tests demonstrated that the energy conversion chain is not negligible at all and an overall net efficiency of the power unit was around 2-3 % with respect to a 10% of thermodynamic efficiency.

© 2017 The Authors. Published by Elsevier Ltd.

Peer-review under responsibility of the scientific committee of the IV International Seminar on ORC Power Systems.

*Keywords:* Waste heat recovery; ORC; axial turbine

---

## 1. Introduction

CO<sub>2</sub> reduction is the actual technological driver in reciprocating internal combustion engines (ICE) research, considering the worldwide greenhouse reduction targets commitment. There are several technological options under development or already in the market that answer to this need. One of them that has great expectations is the energy recovery from exhaust gases. In fact, they waste 35-40% of the fuel energy of an ICE and such recovery could bring

huge efficiency improvement. When this recovery is done through a thermodynamic conversion, the ICE exhaust heat is transferred into a fluid which vaporizes and evolves in an expander, which produces mechanical power. This recovery plant are the so-called ORC (Organic Rankine Cycle) based power units [1] in which working fluid selection is one of the most important issues [2] [3], in particular for low temperature thermal sources [4].

Nomenclature		subscripts	
1	ORC circuit point 1	cond	condenser, condensing
2	ORC circuit point 2	desh	desuperheating
3	ORC circuit point 3	el	electrical
4	ORC circuit point 4	ex	exergetic
AC/DC	alternate/direct current	gas	exhaust gases
h	enthalpy	hs	hot source
HRVG	heat recovery vapor generator	in	inlet
I	irreversibility	mech	mechanical
ICE	Internal Combustion Engine	out	outlet
$\dot{m}$	mass flow rate	plant	whole ORC plant
ORC	Organic Rankine Cycle	pump	pump
p	pressure	ref	reference state
P	mechanical power	sh	superheating
Q	thermal power	th	thermodynamic
s	entropy	turb	turbine
T	temperature	vap	evaporation
$\varepsilon$	effectiveness (NTU method)	water	condenser cooling water
$\eta$	efficiency	WF	working fluid

From a technological point of view, the design challenge in an ORC recovery system is small and micro scale expander machine [5] which operates with unconventional fluids [6]. Volumetric expanders have been widely considered for their high range of applicability: scroll [7] and screw [9] expanders have been reported as among the most suitable solutions for micro and small scale applications [8]. Isentropic efficiency up to 73 % can be achieved ([10], [11]), with a nominal electrical output power from 1 to 2.5 kW with R245fa as working fluid ([12],[13]). Oil-free expanders, moreover, simplify the ORC system design due to the absence of oil circulation and recovery components [14]. A parallel expander configuration of ORC was reported in [15]. Screw expander has been widely investigated for a maximum power output of 10 kW [16]. Rotary vane expanders also have good potentiality, in particular for manageability, simplicity of maintenance, compactness and cost [17]. They showed isentropic efficiency of about 50-60% with recovered power up to 2 kW [18] [19]. More recently, among the volumetric machines, swash-plate expanders were introduced with isentropic efficiency of about 35-40 % and volumetric efficiency in the range of 10-35% [20]. Reciprocating expanders could be considered too ([21] [22]) but they do not seem to add any further advantage, being the disadvantages added fully worth of attention (vibrations, dimensions, etc.). Finally, rotary volumetric expander based on the Wankel concept has been studied, demonstrating good performances in terms of isentropic efficiency (0.8-0.85) for small-medium thermal power applications and the possibility to adjust the revolution speed [23].

Dynamic machines have higher efficiencies and power output, but they need care about inlet thermodynamic fluid conditions and they could need a gear in order to match the revolution speed of a common electrical generator. Axial turbine application to ORC has been studied ([24],[25]) for low to medium power outputs. Improved analyses on cycle performance have been proposed considering the optimum efficiency potential of a radial-inflow expander [26] and radial-outflow technology [27]. Furthermore, it is demonstrated that turbine efficiency (both for axial and radial ones) should be inserted in the design process of an ORC unit, showing high importance in the optimization of a recovery plant [28].

Summarizing, dynamic (axial) machines are characterized by a very low weight to power ratio [29]; this aspect is particularly suitable in the mobile sector [30]. In this paper a single impulse axial turbine has been tested in order to assess the real performances considering the specific environment. The experimental activity considered also the

conversion into electrical energy (produced at variable frequency) and an advanced conversion section into DC for electrical energy storage at 24 V. This required the setup of an ORC-based waste heat recovery unit bottoming a heavy duty engine. Gases at the exhaust were considered as thermal sources. The unit has been instrumented in order to allow most relevant measures. A result of this activity was the reconstruction of the thermodynamic cycle which opened the way to an exergy analysis too.

## 2. Experimental rig

An experimental test bench has been built in order to assess the real performances of the ORC when it is coupled with an internal combustion engine. Overall performances of the ORC unit have been assessed [31] and a deeper analysis (exergetic) is deemed necessary, in particular to appraise the performance of each single components. The engine taken into consideration is an IVECO NEF 67 turbocharged diesel engine, used for power generation, marine, automotive, industrial and agriculture applications. The engine has been run at 1500 RPM and four different engine loads (45%-60%-75%-90% of the maximum one). Therefore, each component of the ORC-based unit has been prototyped and individually tested. R245fa has been used as working fluid, having suitable design pressure levels for this application. In Figure 1 the position of the sensors is shown along the circuit: pressure transducers and thermocouples are placed in the 1-2-3-4 thermodynamic cycle points. Working fluid mass flow rate is measured by the rotational speed of the volumetric pump (internal gear type), a speed sensor is used to measure revolution speed of the turbine and a Hall effect sensor to measure the DC current (at 24 V) provided by the electric device after the generator. Tap water is used for condenser cooling. Table 1 summarizes measurement devices and related uncertainties.

Table 1: Measurement devices and uncertainties

ORC temperatures	T-thermocouples	$\pm 1^\circ\text{C}$
Pressures	Gems Pressure transducers	$\pm 0.2$ bar
Exhaust gas temperatures	K-thermocouples	$\pm 2.2^\circ\text{C}$
Turbine revolution speed	Hall-effect speed sensor	5 %
DC current	Hall effect LEM sensor	$\pm 1\%$
Water flow rate	Turbine flowmeter	$\pm 1$ l/min

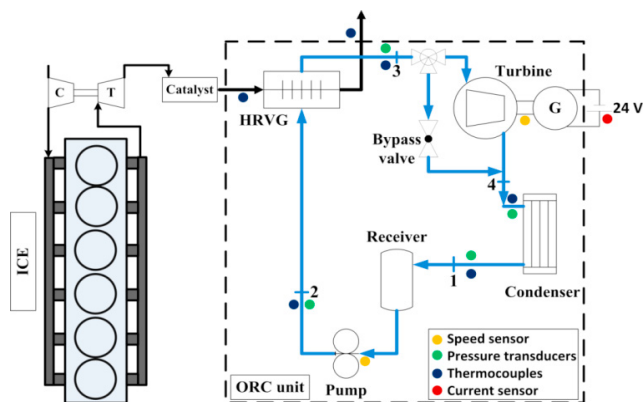

Figure 1: ORC plant test bench

Thanks to a parallel of a battery pack and a variable set of electrical resistances, the load was adjusted according to the turbine revolution speed. A turbine bypass valve is positioned in a parallel branch of the circuit in order to avoid two-phase flow at the turbine inlet and adjust the transient behavior of the unit: during warming up, in fact, the evaporator is unable to superheat the working fluid, and a two-phase flow would damage the turbine blades and the fluid is sent-directly to the condenser.

### 2.1. Heat recovery vapor generator

The heat recovery vapor generator (HRVG) is a heat exchanger which has the role to transfer thermal power from the hot source (i.e. ICE exhaust gases) to the working fluid. The efficiency of this component depends from inlet and outlet temperatures of the fluids and from mass flow rates: in Figure 2 the experimental characterization of a finned coil HRVG chosen for this application, with R245fa as working fluid. Its effectiveness (defined as the ratio between the actual heat rate and the maximum available heat rate, according the NTU method) is about 70%, with a rated thermal power of about 45-50 kW. Its dimensions are 350x350x150 mm, which are well-matched with the exhaust.

### 2.2. Axial turbine

The turbine adopted in this study is a single stage impulse axial one. Figure 3 shows experimental data of isentropic efficiency and thermodynamic power delivered for two different revolution speeds and expansion ratio (i.e. gas flow rate). Maximum rated power is about 7 kW and isentropic efficiency is 80%. Turbine power increases quite linearly with expansion ratio (regardless of speed of revolution) while isentropic efficiency shows an asymptotic trend when pressure ratio increases getting closer to the maximum value (0.8).

Due to the high revolution speed of the turbine (60000-80000 RPM), a gear is needed before the electric conversion. Gear ratio is 10:1 and it needs a separate oil circuit for lubrication. After the speed reduction, the turbine is coupled with an electric generator (Hacker A200 Brushless Motor) that provides AC current. Therefore, it is stored in a 24 V battery pack after a DC conversion.

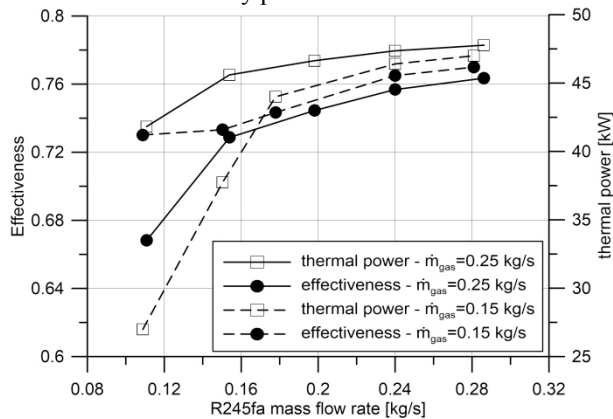

Figure 2: Heat recovery vapor generator experimental performances

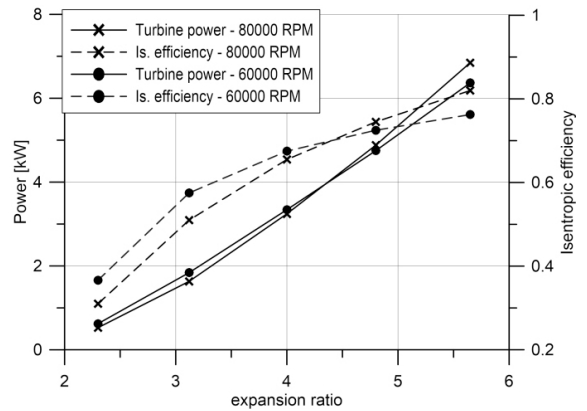

Figure 3: Turbine characterization

### 2.3. Pump

Pump is of an internal gear oil free type, with a suction volume of 6.3 cm<sup>3</sup>. It is coupled to DC motor through a magnetic clutch. Figure 4 shows the experimental characterization of the pump with R245fa as working fluid: the mass flow rate is almost linear with the revolution speed, with a maximum value of about 280 g/s at 2000 RPM. The pump shows a high volumetric efficiency, in the range of 80-98%. Maximum pressure tested is 30 bar, when the electric power absorption is 600 W: this high pressure is interesting in mobile applications which have high condensation temperatures.

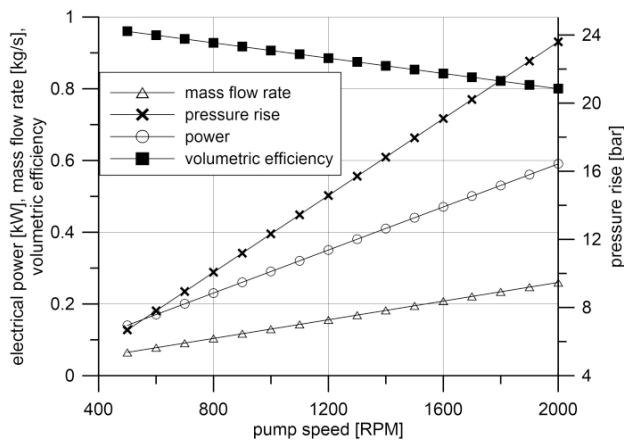

Figure 4: Pump characteristic operation performance

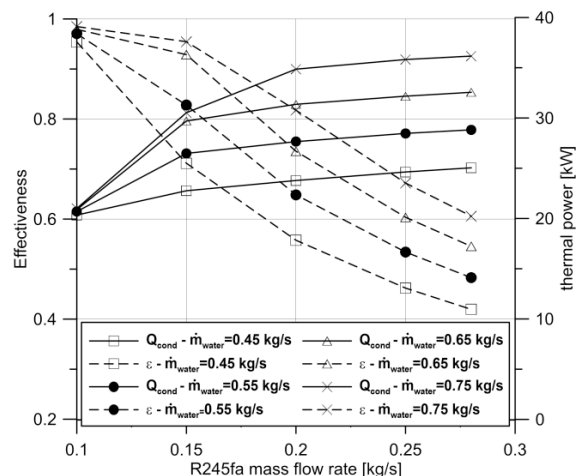

Figure 5: Experimental characterization of the condenser: R245fa at 5 bar and 90°C inlet temperature. Cooling water is at 50°C

## 2.4. Condenser

Condenser is a plate heat exchanger fed by tap water, desuperheating and condensing the working fluid. Heat exchanger dimensions are 180 x 250 x 150 mm. In Figure 5 the effectiveness and the thermal power exchanged when external tap water is entering at 50°C and working fluid (R245fa) at 90°C (5 bar) are reported. These conditions are particularly representative when cooling water is a secondary circuit on a vehicle [32]. In the tests performed, then, tap water flow rate is about 20-25 l/min in order to have condensation temperature in the range of 40-60 °C.

## 3. ORC testing analysis and results

Energy and exergy analysis are based on steady state enthalpy balances across each component, evaluated thanks to pressure and temperature measurement [33]. Equations (1) represent energy balances and equations (2) how irreversibilities have been calculated. ORC thermodynamic and exergetic efficiencies are reported in equations 3 and 4. HVRG efficiency is in equation 5: it has been calculated as the ratio between the heat absorbed by the working fluid and the whole thermal energy owned by the exhaust gas (referred to reference state: 1 bar and 25°C). Overall net energy efficiency of the ORC unit (eq. 6) has been evaluated considering DC electrical power measured after the electrical conversion: hence, it includes mechanical efficiency of the gear and the turbine shaft ( $\eta_{mech,turb}$ ), synchronous generator efficiency conversion and the AC/DC conversion through the electrical rectifier at 24 V ( $\eta_{el,turb}$ ). Also electrical efficiency of the pump motor (DC brushless) has been taken into account in eq.6.

Table 2: Equations used for energy and exergy analysis of the ORC plant

$\begin{cases} Q_{HRVG} = \dot{m}_{WF}(h_3 - h_2) \\ P_{pump} = \dot{m}_{WF}(h_2 - h_1) \\ P_{turb} = \dot{m}_{WF}(h_3 - h_4) \\ Q_{cond} = \dot{m}_{WF}(h_4 - h_1) \end{cases} \quad (1)$	$\begin{cases} I_{HRVG} = T_{ref} [\dot{m}_{WF}(s_3 - s_2) - \dot{m}_{hs}(s_{hs,in} - s_{hs,out})] \\ I_{pump} = P_{pump} - \dot{m}_{WF} [(h_2 - h_1) - T_{ref}(s_2 - s_1)] \\ I_{turb} = \dot{m}_{WF} [(h_3 - h_4) - T_{ref}(s_3 - s_4)] - P_{turb} \\ I_{cond} = \dot{m}_{WF} [(h_4 - h_1) - T_{ref}(s_4 - s_1)] \end{cases} \quad (2)$
$\eta_{th} = \frac{P_{turb} - P_{pump}}{Q_{HRVG}} \quad (3)$	$\eta_{ex} = 1 - \frac{I_{HRVG} + I_{turb} + I_{cond} + I_{pump}}{\dot{m}_{hs} [h_{hs,in} - h_{hs,out} - T_{ref}(s_{hs,in} - s_{hs,out})]} \quad (4)$
$\eta_{HRVG} = \frac{Q_{HRVG}}{Q_{hs}} = \frac{Q_{HRVG}}{\dot{m}_{hs}(h_{hs,in} - h_{hs,ref})} \quad (5)$	$\eta_{plant} = \frac{P_{el,turb} - P_{el,pump}}{Q_{hs}} = \frac{\eta_{el,turb}\eta_{mech,turb}P_{turb} - \frac{P_{pump}}{\eta_{el,pump}}}{Q_{HRVG}} \eta_{HRVG} \quad (6)$

Table 3 shows a summary of the results of the tested performed. The thermal power recovered from the ICE exhaust gases is about 65-70% of the total thermal power available in all the tested cases. This is mainly due to the high temperature of the exhaust gases leaving the HRVG. The working fluid mass flow rate is set regulating the pump speed according to the thermal power recovered: in fact, the working fluid must be completely vaporized after the HRVG passage (in order to run the axial turbine without fluid droplets) and, therefore, at lower engine load (working points A and B), the pump could not be run at high flow rate as in working points C and D. In the table, it is shown also the superheating value ( $\Delta T_{sh}$ ), calculated as in eq. 7, that demonstrates how in lower load working points, the ORC cycle is run just to vaporize all the fluid before the turbine inlet ( $\Delta T_{sh} \approx 0$ ), while in higher working points  $\Delta T_{sh}$  is higher.

$$\Delta T_{sh} = T_3 - T_{vap} \quad (7)$$

In Table 3 is also showed the desuperheating  $\Delta T_{desh}$  value that occurs at the condenser inlet. It is calculated as in eq. 8 and it is important to define the oversizing of the condenser. It depends on the working fluid selected and it is also a useful index of the possibility of a regeneration stage: higher is the  $\Delta T_{desh}$  value, higher is the possibility to use the desuperheating thermal power to heat up the fluid before HRVG and increase ORC thermodynamic efficiency.

$$\Delta T_{desh} = T_4 - T_{cond} \tag{8}$$

Figure 6 shows a comparison between energetic, exergetic and final efficiencies. While thermodynamic efficiency is about 10% for all the performed tests, real efficiency is only about 2.5-3%. This is mainly due to the thermal efficiency of the HRVG (63-76%) and due to the thermodynamic to electric conversion of the turbine work: this passes through the mechanical gear, the electric generator and the current rectifier. Figure 7 summarizes the results of the exergy analysis: major irreversibility is surely happened in the HRVG and they are due to the temperature distance of the hot source from the high pressure vaporization curve of the ORC. It is evident that HRVG irreversibility is higher in high load cases (C and D engine working points), where the mean temperature difference between hot source and ORC is higher. Another remarkable result is the trend of the condenser irreversibility, that is linked to condensing temperature and, so, condensing pressure. Turbine and pump irreversibilities are negligible.

Table 3: Global result of the ORC plant in the ICE working points tested

TEST	units	A	B	C	D
ICE brake power	kW	53	72	93	109
Exhaust gas temperature at HRVG inlet	°C	324.3	382.0	474.1	493.8
Exhaust gas temperature at HRVG outlet	°C	103.0	123.9	151.7	161.4
Thermal power recovered in the HRVG $Q_{hs}$	kW	49.4	62.8	82.0	88.2
Thermal power recovered in the HRVG $Q_{HRVG}$	kW	37.7	43.5	51.8	56.0
HRVG efficiency	%	76.4	69.2	63.1	63.5
ORC evaporating pressure	bar	10.1	12.0	21.9	22.8
ORC condensing pressure	bar	2.45	3.39	4.29	4.78
ORC evaporating temperature $T_{vap}$	°C	97.8	111.7	126.6	128.6
ORC condensing temperature $T_{cond}$	°C	40.2	50.4	58.0	61.7
Evaporating superheating $\Delta T_{sh}$	$\Delta K$	0.4	0.1	9.8	26.6
Condenser desuperheating $\Delta T_{desh}$	$\Delta K$	4.7	1.1	39.9	57.7
Condenser water flow rate	l/min	20	22	25	25
Turbine DC electrical power $P_{el,turb}$	kW	1,49	1,93	2,56	2,55
WF mass flow rate	g/s	150	178	192	192
ORC thermodynamic efficiency ( $\eta_{th}$ )	%	9,9	10,1	9,7	9,9
Exergetic efficiency ( $\eta_{ex}$ )	%	29.0	24.4	18.6	18.9
Overall ORC unit efficiency ( $\eta_{plant}$ )	%	2,57	2,73	2,86	2,72

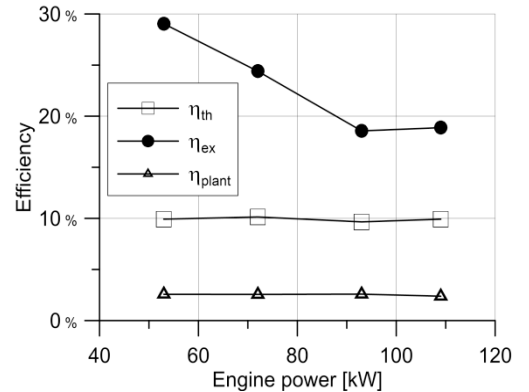

Figure 6: Comparison between exergetic, thermodynamic and final plant efficiencies

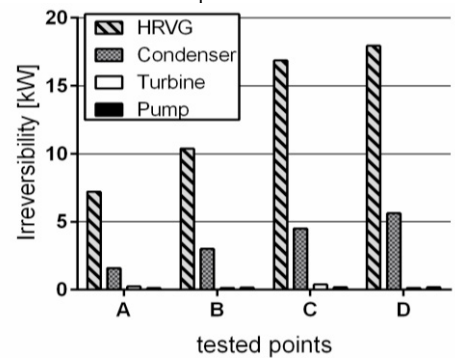

Figure 7: Irreversibilities of the ORC components in the tested points

#### 4. Conclusions

In this work, an experimental assessment of ORC unit bottomed heavy duty ICE has been performed. ICE has been run in the range of brake power between 50 and 110 kW, with a thermal power available in the exhaust gases from 50 to 88 kW. In this application, ORC unit has been equipped with an axial turbine, which presented a low efficiency thermodynamic-to-electric conversion. In fact, while thermodynamic efficiency is about 10% in all tested working points, the final DC electric power is about 2–2.5 kW, showing an overall plant efficiency of about 2–3%. This is mainly due to the above-mentioned conversion chain from thermodynamic to electric power, which is definitively needed in most recovery applications, like on-board vehicle waste heat recovery. Same importance is reserved to compactness of the unit tested: overall dimensions of about 1100x700x700 mm are optimal to be installed on a heavy duty vehicle.

Moreover, exergetic analysis has been carried out, demonstrating that the major source of irreversibilities is concentrated in the heat recovery vapor section, where the thermal distance between the hot source and the evaporating curve of the ORC is huge. This gap can be filled with transcritical ORC, thermodynamic cycles based on gases or new suitable fluids and mixtures with higher critical points.

#### References

- [1] Colonna, P., Casati, E., Trapp, C., Mathijssen, T., Larjola, J., Turunen-Saaresti, T., Uusitalo, A. Organic Rankine Cycle Power Systems: From the Concept to Current Technology, Applications, and an Outlook to the Future (2015) *Journal of Engineering for Gas Turbines and Power*, 137 (10)
- [2] Gianfranco Angelino, Costante Invernizzi, Experimental investigation on the thermal stability of some new zero ODP refrigerants, *International Journal of Refrigeration*, Volume 26, Issue 1, January 2003, Pages 51–58, ISSN 0140-7007,
- [3] Jacopo Vivian, Giovanni Manente, Andrea Lazzaretto, A general framework to select working fluid and configuration of ORCs for low-to-medium temperature heat sources, *Applied Energy*, Volume 156, 15 October 2015, Pages 727–746, ISSN 0306-2619, <http://dx.doi.org/10.1016/j.apenergy.2015.07.005>.
- [4] Adriano Desideri, Sergei Gusev, Martijn van den Broek, Vincent Lemort, Sylvain Quoilin, Experimental comparison of organic fluids for low temperature ORC (organic Rankine cycle) systems for waste heat recovery applications, *Energy*, Volume 97, 15 February 2016, Pages 460–469, ISSN 0360-5442, <http://dx.doi.org/10.1016/j.energy.2015.12.012>.
- [5] Daniele Fiaschi, Gianmaria Innocenti, Giampaolo Manfrida, Francesco Maraschiello, Design of micro radial turboexpanders for ORC power cycles: from 0D to 3D, *Applied Thermal Engineering*, Available online 21 January 2016, ISSN 1359-4311, <http://dx.doi.org/10.1016/j.applthermaleng.2015.11.087>.
- [6] E. Macchi, A. Perdichizzi, Efficiency prediction for axial-flow turbines operating with nonconventional fluids – transactions of the ASME, *J. Eng. Power* 103 (1981) 719.
- [7] P. Song, M. Wei, L. Shi, S. Danish, C. Ma, A review of scroll expanders for organic Rankine cycle systems, *Appl. Therm. Eng.* 75 (2015) 54–64.
- [8] Oudkerk J-F, Quoilin S, Declaye S, Guillaume L, Winandy E, Lemort V. Evaluation of the energy performance of an organic Rankine cycle-based micro combined heat and power system involving a hermetic scroll expander. *J Eng Gas Turbines Power* 2013;135:042306. <http://dx.doi.org/10.1115/1.4023116>.
- [9] Y. Zhu, L. Jiang, V. Jin, L. Yu, Impact of built-in and actual expansion ratio difference of expander on ORC system performance, *Appl. Therm. Eng.* 71 (2014) 548–558.
- [10] Lemort V, Quoilin S, Cuevas C, Lebrun J. Testing and modeling a scroll expander integrated into an organic Rankine cycle. *Appl Therm Eng* 2009;29:3094–102. <http://dx.doi.org/10.1016/j.applthermaleng.2009.04.013>.
- [11] Chang J-C, Hung T-C, He Y-L, Zhang W. Experimental study on lowtemperature organic Rankine cycle utilizing scroll type expander. *Appl Energy* 2015;155:150–9. <http://dx.doi.org/10.1016/j.apenergy.2015.05.118>.
- [12] Gnutek Z, Kolasin´ski P. The application of rotary vane expanders in organic rankine cycle systems—thermodynamic description and experimental results. *J Eng Gas Turbines Power* 2013;135:061901.
- [13] E. Galloni, G. Fontana, S. Staccone, Design and experimental analysis of a mini ORC (organic Rankine cycle) power plant based on R245fa working fluid, *Energy*, Volume 90, Part 1, October 2015, Pages 768–775, ISSN 0360-5442, <http://dx.doi.org/10.1016/j.energy.2015.07.104>.

- [14] Declaye S, Quoilin S, Guillaume L, Lemort V. Experimental study on an opendrive scroll expander integrated into an ORC (organic Rankine cycle) system with R245fa as working fluid. *Energy* 2013;55:173–83.
- [15] Yun E, Kim D, Yoon SY, Kim KC. Experimental investigation of an organic Rankine cycle with multiple expanders used in parallel. *Appl Energy* 2015;145:246–54. <http://dx.doi.org/10.1016/j.apenergy.2015.02.022>.
- [16] Zhang Y-Q, Wu Y-T, Xia G-D, Ma C-F, Ji W-N, Liu S-W, et al. Development and experimental study on organic Rankine cycle system with single-screw expander for waste heat recovery from exhaust of diesel engine. *Energy* 2014;77:499–508. <http://dx.doi.org/10.1016/j.energy.2014.09.034>
- [17] Gnutek Z, Kolasin' ski P. The application of rotary vane expanders in organic rankine cycle systems—thermodynamic description and experimental results. *J Eng Gas Turbines Power* 2013;135:061901.
- [18] Roberto Cipollone, Giuseppe Bianchi, Davide Di Battista, Giulio Contaldi, Stefano Murgia, Mechanical Energy Recovery from Low Grade Thermal Energy Sources, *Energy Procedia*, Vol. 45, 2014, Pages 121-130, ISSN 1876-6102
- [19] Roberto Cipollone, Giuseppe Bianchi, Angelo Gualtieri, Davide Di Battista, Marco Mauriello and Fabio Fatigati, *Development of an Organic Rankine Cycle system for exhaust energy recovery in internal combustion engines*, Journal of Physics: Conference Series, Volume 655, conference 1, 2015
- [20] J. Galindo, S. Ruiz, V. Dolz, L. Royo-Pascual, R. Haller, B. Nicolas, Y. Glavatskaya, Experimental and thermodynamic analysis of a bottoming Organic Rankine Cycle (ORC) of gasoline engine using swash-plate expander, *Energy Conversion and Management*, Volume 103, October 2015, Pages 519-532, ISSN 0196-8904,
- [21] Muhammad Imran, Muhammad Usman, Byung-Sik Park, Dong-Hyun Lee, Volumetric expanders for low grade heat and waste heat recovery applications, *Renewable and Sustainable Energy Reviews*, Volume 57, May 2016, Pages 1090-1109, ISSN 1364-0321, <http://dx.doi.org/10.1016/j.rser.2015.12.139>.
- [22] J F Oudkerk, R Dickes, O Dumont and V Lemort - Experimental performance of a piston expander in a small- scale organic Rankine cycle - IOP Conference Series: Materials Science and Engineering, Volume 90, conference 1
- [23] M. Antonelli, A. Baccioli, M. Francesconi, U. Desideri, L. Martorano, Operating maps of a rotary engine used as an expander for micro-generation with various working fluids, *Applied Energy*, Volume 113, January 2014, Pages 742-750, ISSN 0306-2619, <http://dx.doi.org/10.1016/j.apenergy.2013.08.003>
- [24] Guilherme Leibsohn Martins, Sergio Leal Braga, Sandro Barros Ferreira, Design optimization of partial admission axial turbine for ORC service, *Applied Thermal Engineering*, Volume 96, 5 March 2016, Pages 18-25, ISSN 1359-4311, <http://dx.doi.org/10.1016/j.applthermaleng.2015.09.041>.
- [25] Wenhao Pu, Chen Yue, Dong Han, Weifeng He, Xuan Liu, Qi Zhang, Yitung Chen, Experimental study on Organic Rankine cycle for low grade thermal energy recovery, *Applied Thermal Engineering*, Volume 94, 5 February 2016, Pages 221-227, ISSN 1359-4311, <http://dx.doi.org/10.1016/j.applthermaleng.2015.09.120>.
- [26] Yan Li, Xiao-dong Ren, Investigation of the organic Rankine cycle (ORC) system and the radial-inflow turbine design, *Applied Thermal Engineering*, Volume 96, 5 March 2016, Pages 547-554, ISSN 1359-4311,
- [27] C. Spadacini, D. Rizzi, C. Saccilotto, S. Salgarollo, L. Centemeri The radial outflow turbine technology – impact on the cycle, thermodynamics, machinery fluid and rotor dynamic features. ASME ORC 2013 – 2nd International Seminar on ORC Power Systems, October 2013, Netherlands
- [28] Giovanni Manente, Luca Da Lio, Andrea Lazzaretto, Influence of axial turbine efficiency maps on the performance of subcritical and supercritical Organic Rankine Cycle systems, *Energy*, Volume 107, 15 July 2016, Pages 761-772, ISSN 0360-5442, <http://dx.doi.org/10.1016/j.energy.2016.04.063>.
- [29] Capata, R.; Hernandez, G. Preliminary Design and Simulation of a Turbo Expander for Small Rated Power Organic Rankine Cycle (ORC). *Energies* 2014, 7, 7067-7093.
- [30] D. Di Battista, M. Mauriello, R. Cipollone - Waste heat recovery of an ORC-based power unit in a turbocharged diesel engine propelling a light duty vehicle - *Applied Energy* 152 (2015) 109–120
- [31] Cipollone, R., Di Battista, D., Perosino, A., and Bettoja, F., "Waste Heat Recovery by an Organic Rankine Cycle for Heavy Duty Vehicles," *SAE Technical Paper* 2016-01-0234, 2016, doi:10.4271/2016-01-0234.
- [32] R. Cipollone, D. Di Battista, A. Gualtieri - A novel engine cooling system with two circuits operating at different temperatures - *Energy Conversion and Management* 75 (2013) 581–592
- [33] D. Di Battista, R. Cipollone, C. Villante, C. Fornari, M. Mauriello, The Potential of Mixtures of Pure Fluids in ORC-based Power Units fed by Exhaust Gases in Internal Combustion Engines, *Energy Procedia*, Volume 101, November 2016, Pages 1264-1271, ISSN 1876-6102, <http://dx.doi.org/10.1016/j.egypro.2016.11.142>.